

SAN ANTONIO WATER SYSTEM PURCHASING DEPARTMENT

Issued By: **D. Anthony Rubin**
BID NO.: 20-20084

Date Issued: August 11, 2020

**FORMAL INVITATION FOR BIDS
CONTRACT FOR PURCHASE OF AERATOR GEARBOX UNIT
ADDENDUM NO. 1**

Sealed bids addressed to the Purchasing Director, San Antonio Water System, 2800 US Hwy 281 North, Administration Bldg., 5th Floor, San Antonio, TX 78212 will be received until **3:00 p.m., August 20, 2020** and then publicly opened and read aloud for furnishing materials or services as described herein below,

The San Antonio Water System Purchasing Department is willing to assist any bidder(s) in the interpretation of bid provisions or explanation of how bid forms are to be completed. Assistance may be received by visiting the Purchasing Office in the SAWS Main Office, 2800 US Hwy 281 North, San Antonio, TX 78212, or by calling (210) 233-3819.

This invitation includes the following:

Invitation for Bids
Terms and Conditions of Invitation for Bids

Specifications and General Requirements
Price Schedule

The undersigned, by his/her signature, represents that he/she is authorized to bind the Bidder to fully comply with the Specifications and General Requirements for the amount(s) shown on the accompanying bid sheet(s). By signing below, Bidder has read the entire document and agreed to the terms therein.

Signer's Name: _____ Firm Name: _____
(Please Print or Type)

Address: _____

Signature of Person Authorized to Sign Bid _____ City, State, Zip Code: _____

Email Address: _____ Telephone No.: _____

Fax No.: _____

Please complete the following:

Prompt Payment Discount: _____% _____days. (If no discount is offered, Net 30 will apply.)

Please check the following blanks which apply to your company:

Ownership of firm (51% or more):

Non-minority Hispanic African-American Other Minority (specify) _____

Female Owned Handicapped Owned Small Business (less than \$1 million annual receipts or 100 employees)

Indicate Status: Partnership Corporation Sole Proprietorship Other (specify) _____

Tax Identification Number: _____

To report suspected ethics violations impacting the San Antonio Water System, please call 1-800-687-1918.

This **Addendum no. 1** is being issued for **Contract for Purchase of Aerator Gearbox Unit bid no. 20-20084** to provide responses to Question submitted.

Question received for bid no. 20-20084 Purchase of Aerator Gearbox Unit

1. Motor adaptor is listed as 445 LP. Can you confirm the Motor HP and RPM? ANSWER: 150 HP on VFD. 1785 RPM
2. There are two outline drawings, one shows a low speed drop bearing housing the other does not, is it available? ANSWER: It has the drop down bearing
3. Please provide axial loads? ANSWER: Not available
4. What is the gearbox ratio? ANSWER: 52.976:1
5. The drawing provided is not very clear. Is there a clear drawing available? ANSWER: No
6. Can you please send us a sketch or at least name of manufacturer? ANSWER: Flender
7. The drawings attached to the bid we note that they depict two different reducers – one with an extended bearing arrangement and motor adapter. Which version do you require? ANSWER: With extended bearing arrangement and motor adapter.

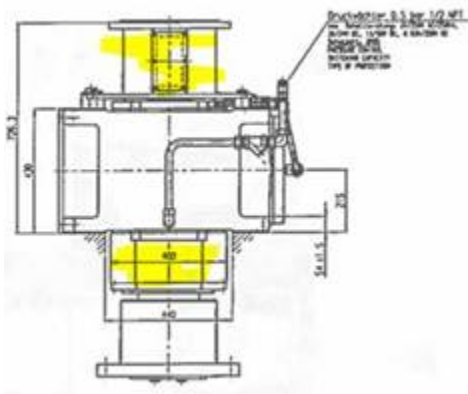

The other drawing is with the extended bearing

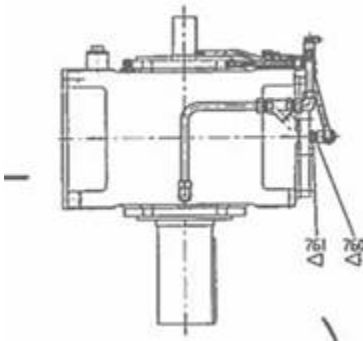

IT IS NOT NECESSARY TO RETURN THIS ADDENDUM.